



Prof. Masahiro SAKANO, [peg03032@nifty.com](mailto:peg03032@nifty.com)  
Kansai University, Osaka, Japan  
Kentaro MATSUMOTO, [matsumoto\\_kentarou@railtec.jp](mailto:matsumoto_kentarou@railtec.jp)  
Railtec Co., Osaka, Japan  
Dr. Hironori NAMIKI  
Kyobashi Mentec Co.Ltd., Osaka, Japan

## STEEL PLATE PRE-STRESSING REINFORCEMENT FOR NOTCHED STEEL GIRDER ENDS

### WSTĘPNE SPRĘŻENIE WZMOCNIENIA ŚRODNIA DŹWIGARA STALOWEGO Z PODCIĘTYM KOŃCEM

**Abstract** The applicability of the steel plate pre-stressing method is investigated for the purpose of preventing fatigue crack propagation to the web in the notched girder end. With the steel plate pre-stress method, it is considered to be possible for the reinforcing plate to be decreased in size in comparison with the conventional reinforcing method, since both live load and dead-load can be reduced or changed to compressive stress by compressive pre-stressing. Monotonic and fatigue loading tests are reported using full-scale girder specimens with notch.

**Streszczenie** Analizowano możliwość wstępnego sprężenia środnika podciętego końca dźwigara stalowego w celu zapobiegania rozprzestrzeniania się pęknięć zmęczeniowych. Stosując sprężenie środnika uznano, że możliwe będzie zmniejszenie wymiarów elementów wzmacniających w porównaniu z konwencjonalnym wzmocnieniem, gdyż naprężenia zarówno od obciążenia użytkowego jak i ciężaru własnego mogą być dzięki wstępnemu sprężeniu ścisłującemu zredukowane lub zamienione na naprężenia ściskające. Przedstawiono wyniki badań Pd obciążeniem stałym jak i zmęczeniowym z wykorzystaniem dźwigarów z podcięciem wykonanych w skali naturalnej.

### 1. Introduction

It has been extensively reported that fatigue cracks have been detected at notched steel girder ends, which are reinforced by using ribbed steel plate. However, the conventional reinforcement method may not always be perfect in its response to actual conditions, since the size of the reinforcing plate cannot always be sufficient, due to limited space with stiffeners or various attachment members in the notched girder end. There is also a possibility that sufficient friction grip connection is not produced by the reinforcing plate rib when the reinforcing plate is fixed on to the web. So, it has been reported that fatigue cracks were again propagated after reinforcement.

In this study, the applicability of the steel plate pre-stressing method is investigated for the purpose of preventing fatigue crack propagation to the web in the notched girder end. The steel plate pre-stress method is also considered to have the potential for decrease in size of the rein-

forcing plate in comparison with the conventional reinforcing method, since both live load stress and dead load tensile stress can be reduced or changed to compressive stress by compressive pre-stressing. In this paper, monotonic and fatigue loading tests are reported using full-scale girder specimens with notch.

## 2. Experimental Method

### 2.1 Specimens

Fig. 1 shows the configuration and dimensions of the notched steel girder specimen. The specimens were designed so that the girder end with the notch (radius of 80mm) can be exchanged, and the other part can be used repeatedly. The material used was JIS SS400 Steel. Three parts of the girder end were prepared, respectively for three cases of no reinforcement, steel plate reinforcement and steel plate pre-stressing reinforcement.

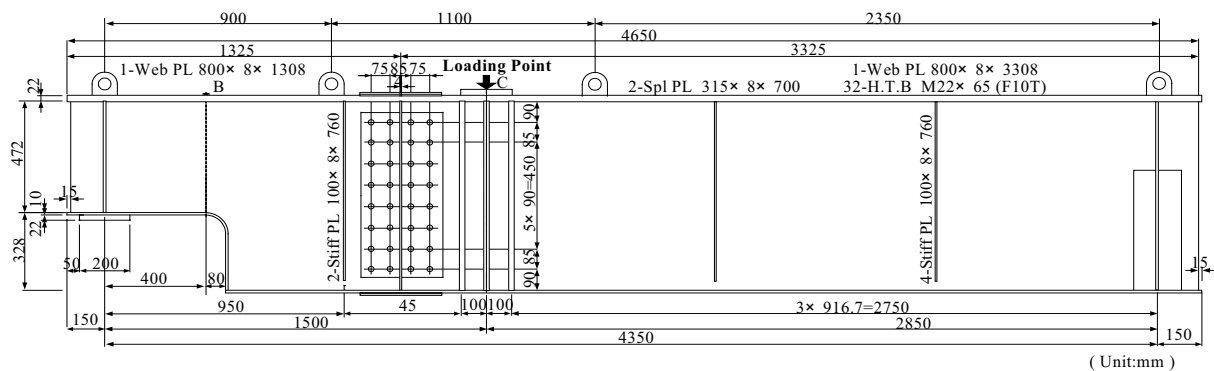

Fig. 1 Notched girder specimen (elevation)

In the loading condition, the specimen is simply supported and loaded at the point of 1/3 of the span so that a sufficient shearing force and bending moment can be applied in the notched girder end. The maximum load is set at 300kN, so that the maximum stress which occurs in the bottom flange may remain within the static allowable stress for the material.

### 2.2 Steel plate reinforcement

In the specimen with steel plate reinforcement, the reinforcing steel plate is installed to the notched girder end by a friction grip connection using high-strength bolts (see Fig. 2). Angle steels as reinforcing members (90mm×90mm×670mm) are installed on the face and back of the web, and then fixed to both the bottom flange in the small section and the web in the large section. This steel plate reinforcing method is expected to reduce the stress concentra-

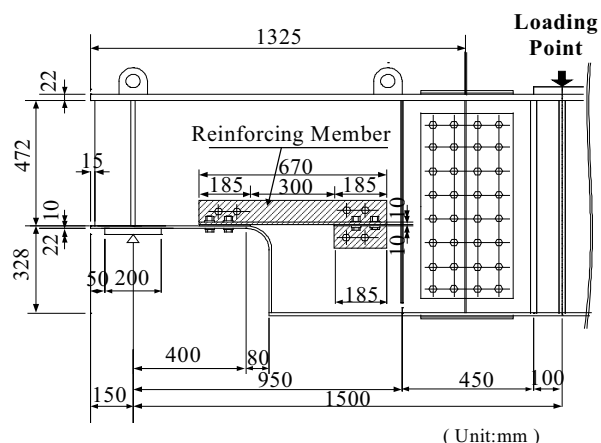

Fig. 2 Reinforcing the Notched girder Specimen

tion of notched members and extend the fatigue life, because stress in the bottom flange in the small section is transmitted to the web in the large section.

### 2.3 Steel plate pre-stressing method

Pre-stresses are introduced into the notch using a heating and cooling process. Pre-stressing processes are as follows (see Fig.3).

Step 1: Fix one end of the reinforcing steel plate to the web of the large section side near the loading-point side using high-strength bolts.

Step 2: Heat the reinforcing plate using gas burners.

Step 3: Fix the other end of the reinforcing plate when its elongation reaches the expected value.

Step 4: Cool the reinforcing steel plate. During these processes, tensile stress should be introduced into the reinforcing plate and compressive stress should be introduced into the bottom flange of the reinforced beam.

The elongation of the reinforcing plate was monitored and controlled by using a dial meter. The reinforcing method should ensure that the stress concentration can be reduced by installing

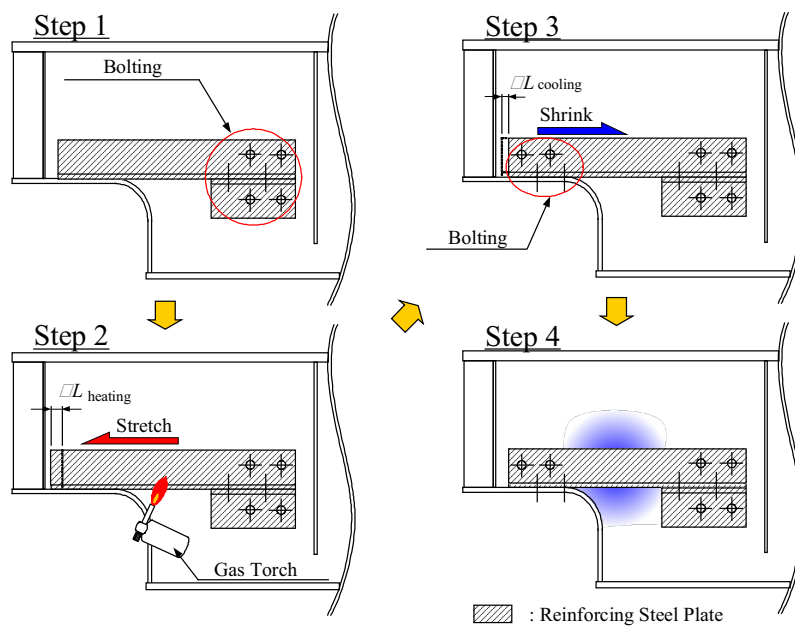

Fig. 3 Reinforcing the Notched girder Specimen

reinforcing plates, and fatigue crack is prevented from propagating to the web by compressive pre-stress.

## 3. Experimental results

### 3.1 Pre-stressing process

Fig. 4 shows changes of stress and temperature during the pre-stressing process. Tensile stress is introduced into the reinforcing plate, and compressive stress is introduced into the web near

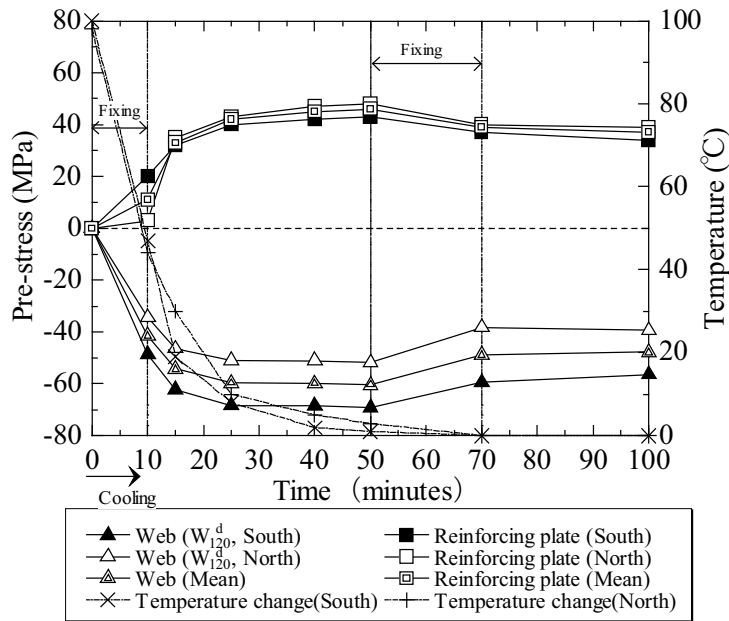

Fig. 4 Change of stresses during pre-stressing

the notch during the cooling process. It takes about half an hour for the pre-stressing process to be completed.

### 3.2 Static loading test results

Fig. 5 shows the change in horizontal stresses in the web (Test point W120d ) behind the center of the reinforcing plate during the loading process. In the specimen without reinforcement, the relations between horizontal stress and the magnitude of load ( $\circ$ ) are distributed linearly, and horizontal stress is about 80MPa when the load is maximum ( $P_{max}=300kN$ ).

In the specimen with steel plate reinforcement, the horizontal stress in the web ( $\Delta$ ) can be reduced when  $P > 60kN$  in comparison with the specimen without reinforcement, because the specimen was reinforced when  $P_{min}=60kN$  which was assumed to be a dead load. On the other hand, the stress ( $\blacktriangle$ ) in the reinforcing steel plate was increasing as decreasing the stress in the web.

The stress under maximum load ( $P_{max}=300kN$ ) is reduced 40% from 75MPa to 45MPa compared to the specimen without rein-

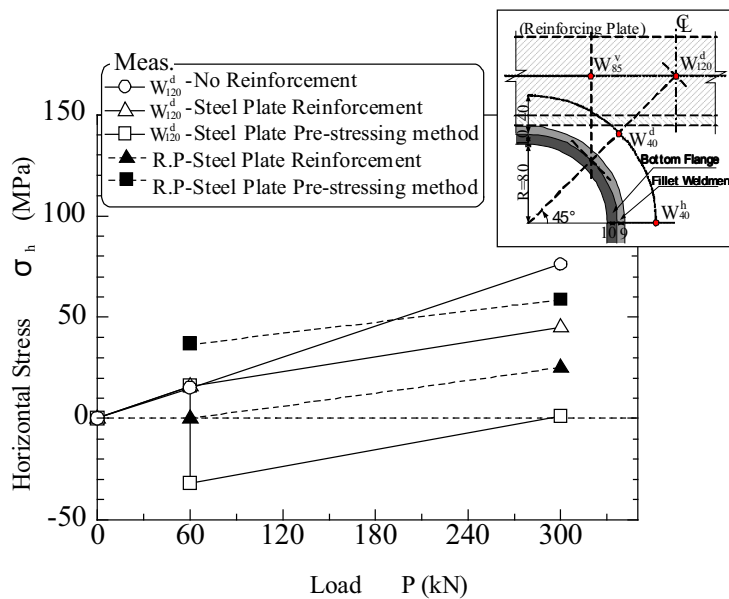

Fig. 5 Relation between horizontal stress and load

forcement. The stress in the reinforcing steel plate is about 25MPa.

In the specimen with steel plate pre-stressing reinforcement, the pre-stress was also introduced into the web during dead loading ( $P_{min}=60kN$ ). Tensile stress 40MPa was introduced by the reinforcing steel plate and compressive stress -50MPa in the web plate. Although the gradients of the stress change in web and reinforcing steel plate ( $\square$ ,  $\blacksquare$ ) in the specimen with steel plate pre-stressing reinforcement are almost same as those in the specimen with steel plate reinforcement ( $\Delta$ ,  $\blacktriangle$ ) when  $P>60kN$ , the web stress ( $\square$ ) is compressive, and becomes about 0MPa when maximum loading. Consequently, the horizontal stress range in the web( $\square$ ) during cyclic loading stays in the compressive area. The stress( $\blacksquare$ ) in the reinforcing steel plate with pre-stress is 40MP larger, which is exactly same as the magnitude of the pre-stress, than stress( $\blacktriangle$ ) in the reinforcement steel plate without pre-stress.

Fig. 6 shows the principal stress distributions in the web near the notch during live loading. In the specimen without reinforcement, the magnitude of measured maximum principal stress range of 99MPa is almost horizontal at test point W40d. In the specimen with steel plate reinforcement, the maximum principal stress range (test point W40d) near the center of the notched corner is reduced to 65MPa. Thus, it is confirmed that the stress concentration of a notched corner is re-

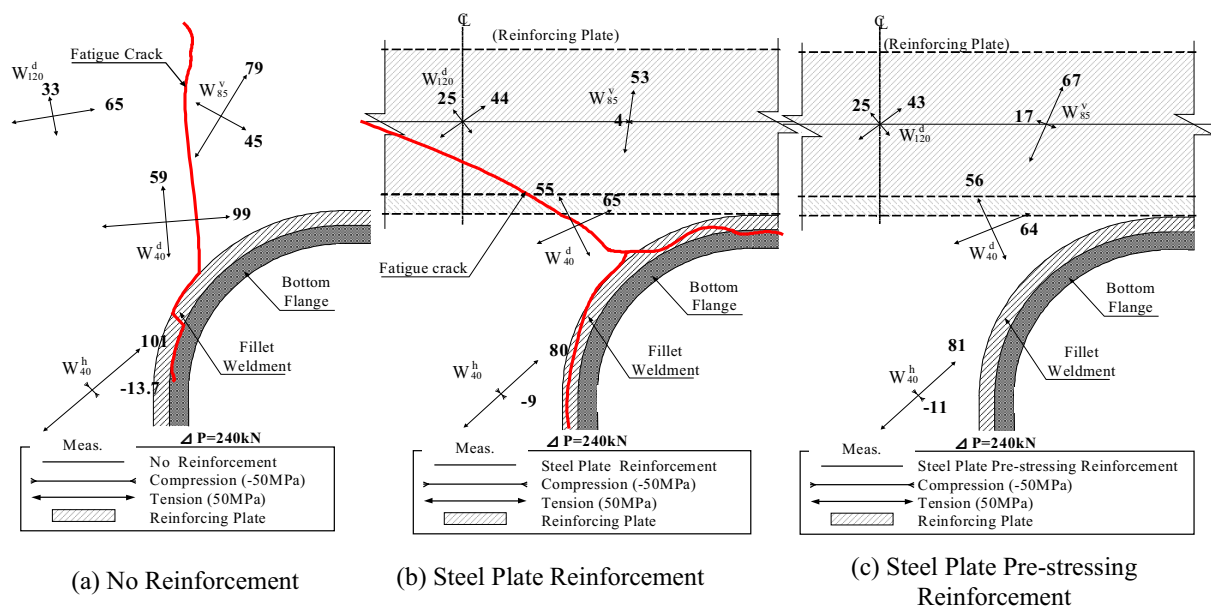

Fig. 6 Maximum principal stress range distribution under the live loading ( $\Delta P=240kN$ )

duced by steel plate reinforcement. In the specimen with steel plate pre-stressing reinforcement, the magnitude and direction of the principal stress range distribution is almost the same as that in the specimen with steel plate reinforcement under cyclic loading., as shown in Fig. 6 (b),(c).

Fig.7 shows the principal stress distribution in the web near the notch when maximum loading ( $P_{max}=300kN$ ). The magnitude of the principal stress of both specimen without reinforcement and specimen with steel plate reinforcement increase corresponding to increase in the magnitude of load, in comparison with Fig. 6. In the steel plate pre-stressed specimen, the horizontal stress of the web behind the reinforcing plate (test points W85V and W120d) changed to compression

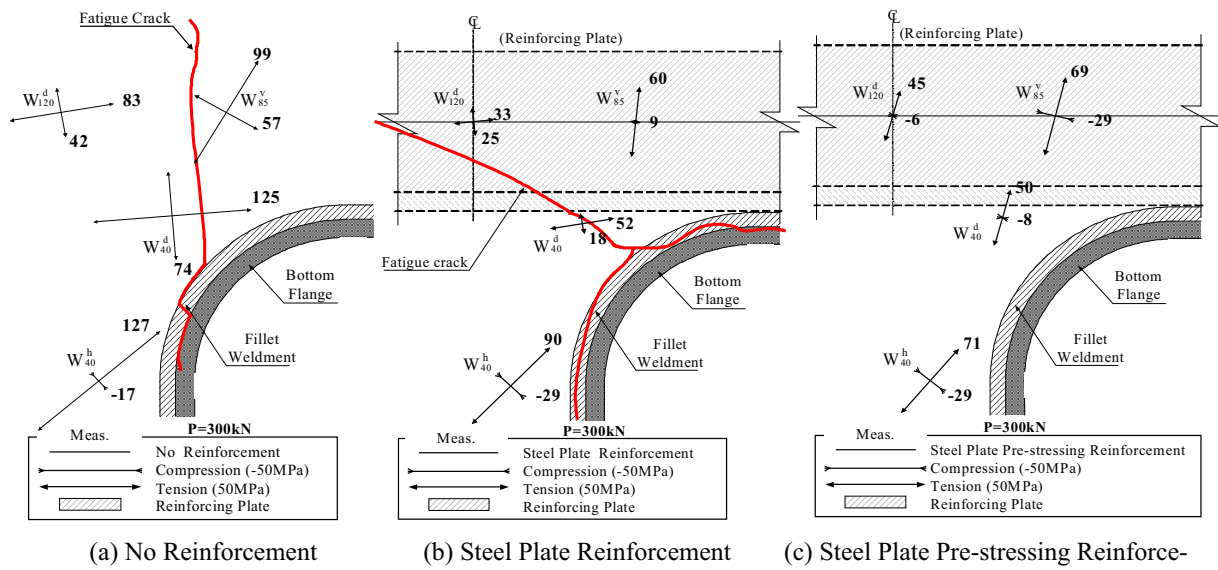

Fig.7 Maximum principal stress distribution when maximum loading ( $P_{max}=300kN$ )

by introduced compressive pre-stress. And the horizontal stress near the center of the notched corner (test point W40d) is also introduced compressive

### 3.3 Fatigue test results

#### 3.3.1 Fatigue behaviour

Photo 1, 2 show fatigue crack initiation and propagation behaviour in the specimen without reinforcement. Root cracks were detected along the fillet welds between web and bottom flange in

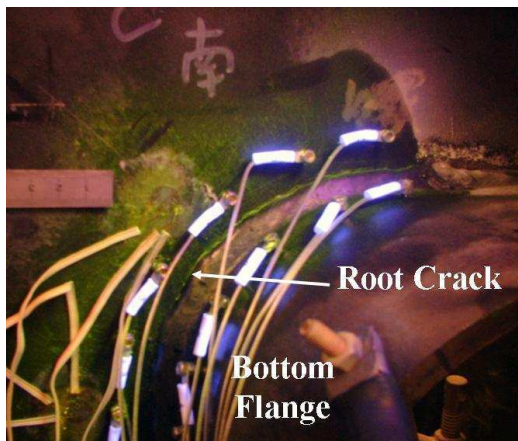

Photo 1 Detected Fatigue Crack in the specimen without reinforcement ( $N_d = 1.7M$ cycles,  $2a = 20mm$ )

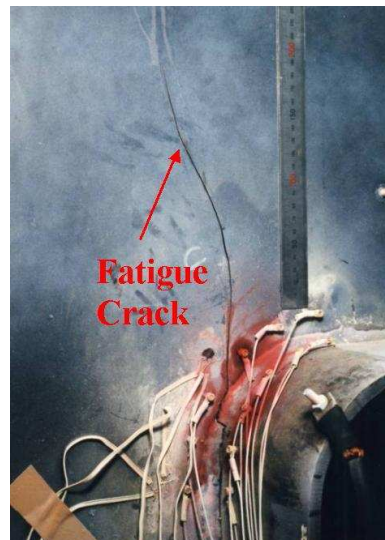

Photo 2 Propagated Fatigue Crack in the specimen without reinforcement ( $N_f = 2.05M$ cycles,  $2a = 315mm$ )

the middle of a notched corner at 1.7 Mcycles (Photo 1), and propagated vertically to break the web quickly at 2.1 Mcycles (Photo 2). The direction of fatigue crack propagation in the web is almost perpendicular to the direction of maximum principal stress in Fig. 6.

Photo 3 shows the fracture surface. Fatigue cracks started from several points along the non-deposited zone, and propagated from weldment to the web. It seems that fatigue cracks quickly propagated after penetrated the plate thickness. The root gap between web and bottom flange could hardly be detected.

Photo 4, 5 show fatigue crack initiation and propagation behaviour in the specimen with steel plate reinforcement. Root cracks were also detected along the fillet welds between web and bottom flange in the middle of the notched corner at 4.3

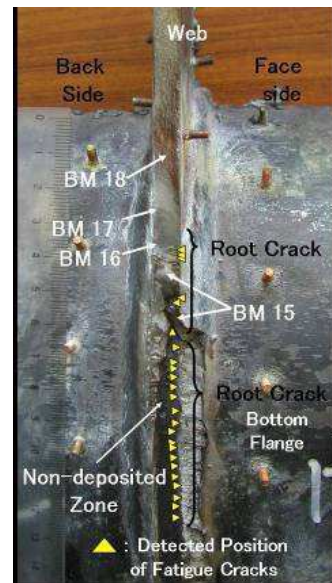

Photo 3 Fracture surface in the specimen without reinforcement

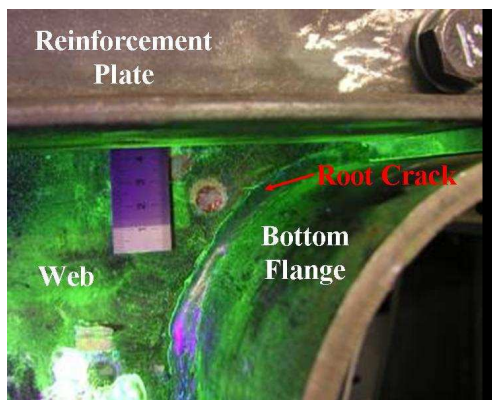

Photo 4 Detected Fatigue Crack in the specimen with steel plate reinforcement (Nd = 4.27 Mcycles, 2a = 5mm)

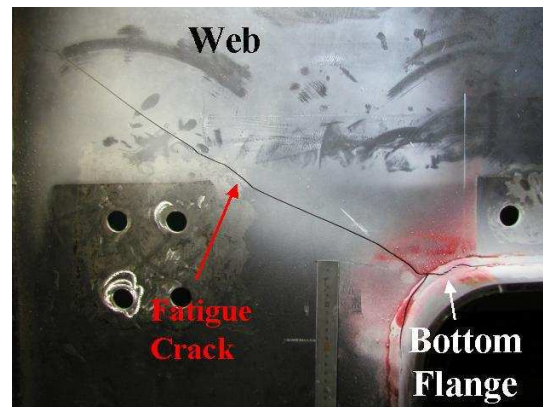

Photo 5 Propagated Fatigue Crack in the specimen with steel plate reinforcement (Nf = 10.15 Mcycles, 2a = 583mm)

Mcycles (Photo 4), after propagating into the web at 4.8 Mcycles, and propagated diagonally and slowly to break the web at 10.2 Mcycles (Photo 5).

In the specimen with steel plate pre-stressing reinforcement, no fatigue cracks were detected in the notched girder end.

Fig. 8 shows fatigue crack propagation curves in all specimens. The vertical axis is fatigue crack length.

The horizontal axis is the number of cycles life. In the specimen without reinforcement, fatigue cracks were detected very early (1.7

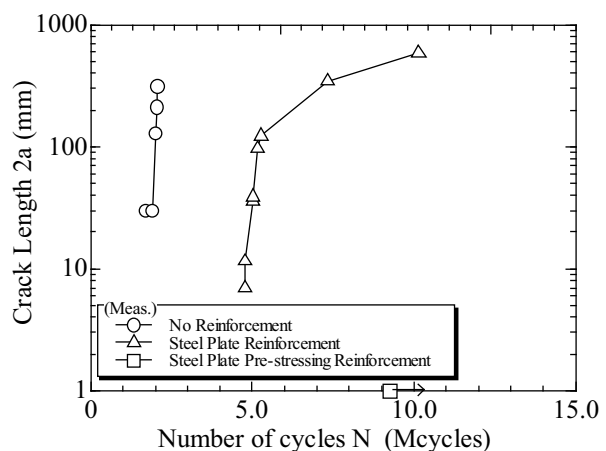

Fig.8 Fatigue crack propagation curves

Mcycles) and break quickly (2.1 Mcycles). In the specimen with steel plate reinforcement, fatigue cracks were detected late (4.3 Mcycles) and also propagated slowly (10.2 Mcycles). In the specimen with steel plate pre-stressing reinforcement, no fatigue cracks were detected until 9.3 Mcycles.

### 3.3.2 Fatigue behaviour

Fig. 9 shows fatigue life of specimens and fatigue design curves from the JRA Recommendations (2002). The JRA categorizes root cracking of load carrying fillet weld joint as Class H. The fatigue strength of the specimen without reinforcement satisfies Class G of the JRA recommendations. The fatigue strength of the specimens with steel plate reinforcement satisfies Class F, one rank higher than Class G. Furthermore, the fatigue strength of the specimen with the steel plate pre-stressing reinforcement satisfies not less than the fatigue Class F.

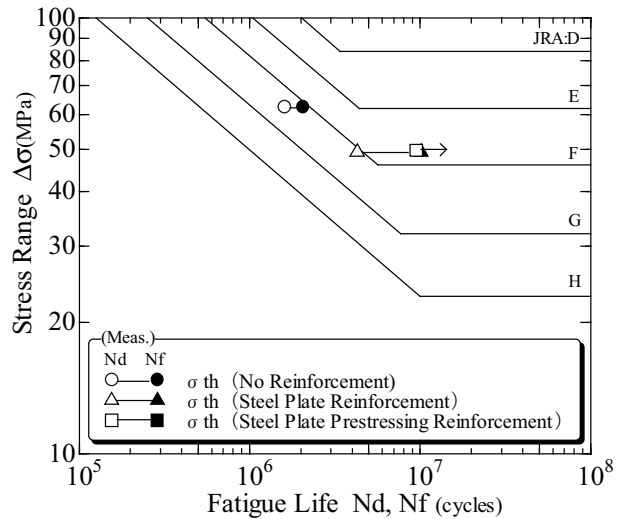

Fig.9 Fatigue strength

### 3.3.3 Effect of Pre-stress

It was noticed that reduction of mean stress improved fatigue strength of the specimen by the plate pre-stressing method described in Section 3.3.2. Fig.10 shows the relation between mean stress and fatigue strength. The vertical axis is 2.0 Mcycles fatigue strength. The horizontal axis is the mean stress in the cross-section of the throat in fillet welds between web and bottom flange in the middle of a notched corner. The reduction of mean stress between the no-reinforcement specimen (○) and the steel plate reinforcement specimen (Δ) causes from the reduction of stress range by steel plate reinforcement. The reduction of mean stress between the steel plate reinforcement specimen and the steel plate pre-stressing reinforcement specimen (□) causes from the effect of pre-stressing. It was verified that the remarkable improvement of fatigue strength by

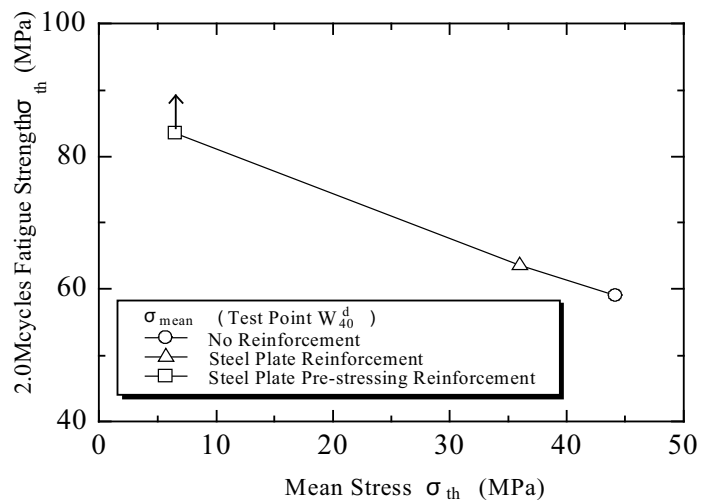

Fig.10 Mean stress and fatigue strength range



steel plate pre-stressing reinforcement comes from the effect of mean stress reduction by the pre-stressing.

#### 4. Conclusions

The principal results obtained through this study are as follows;

It was verified that sufficient compressive pre-stress can be introduced into both web and weldment in the notched girder end using the steel plate pre-stressing method.

In the specimen without reinforcement, fatigue cracks were detected along the fillet welds between web and bottom flange in the middle of the notched corner, and propagated vertically and quickly to break the web. In the specimen with steel plate reinforcement, fatigue cracks were also detected along the fillet welds between web and bottom flange in the middle of the notched corner, but propagated diagonally and slowly to break the web. In the specimen with steel plate pre-stressing reinforcement, no fatigue cracks were detected in the notched girder end.

The fatigue strength of the specimen without reinforcement satisfies Class G of the JRA recommendations. The fatigue strength of the specimens with steel plate reinforcement satisfies Class F, which is one rank higher than Class G. Furthermore, the fatigue strength of the specimen with the steel plate pre-stressing reinforcement satisfies the fatigue class not less than Class F. It was verified that the remarkable improvement of fatigue strength by steel plate pre-stressing reinforcement comes from the effect of mean stress reduction by the pre-stressing.

#### Reference

1. Hanshin Expressway Public Corporation: An Investigation of soundness in Notched Steel Girder Ends, 1983. (in Japanese)
2. M. Sakano, H. Namiki, N. Horikawa, S. Yamamoto and Y. Osakada: Reinforcement of Steel Beams Using High-Strength Steel Plates with Prestressing, Proceedings of the 1st International Conference on Bridge Maintenance, Safety and Management, Barcelona, Spain (on CD-ROM) , 2002.
3. Japan Road Association: Fatigue of Steel Bridges, 1997. (in Japanese)

